

FUEL OUT  
 $\phi 9 \times \phi 7 \times R3/8$   
 Hose nipple

FUEL IN  
 $\phi 9 \times \phi 7 \times R3/8$   
 Hose nipple

Air purging valve

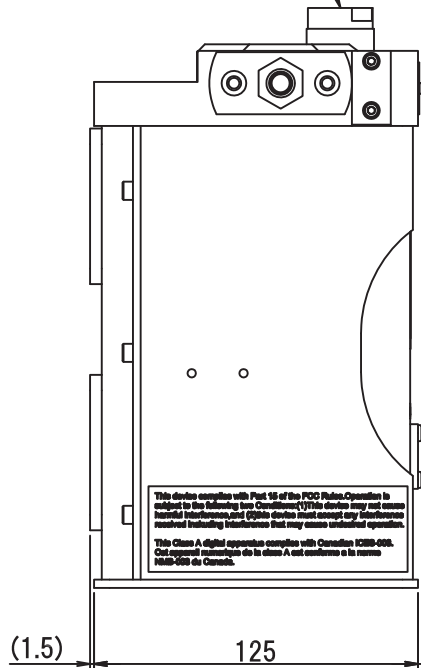
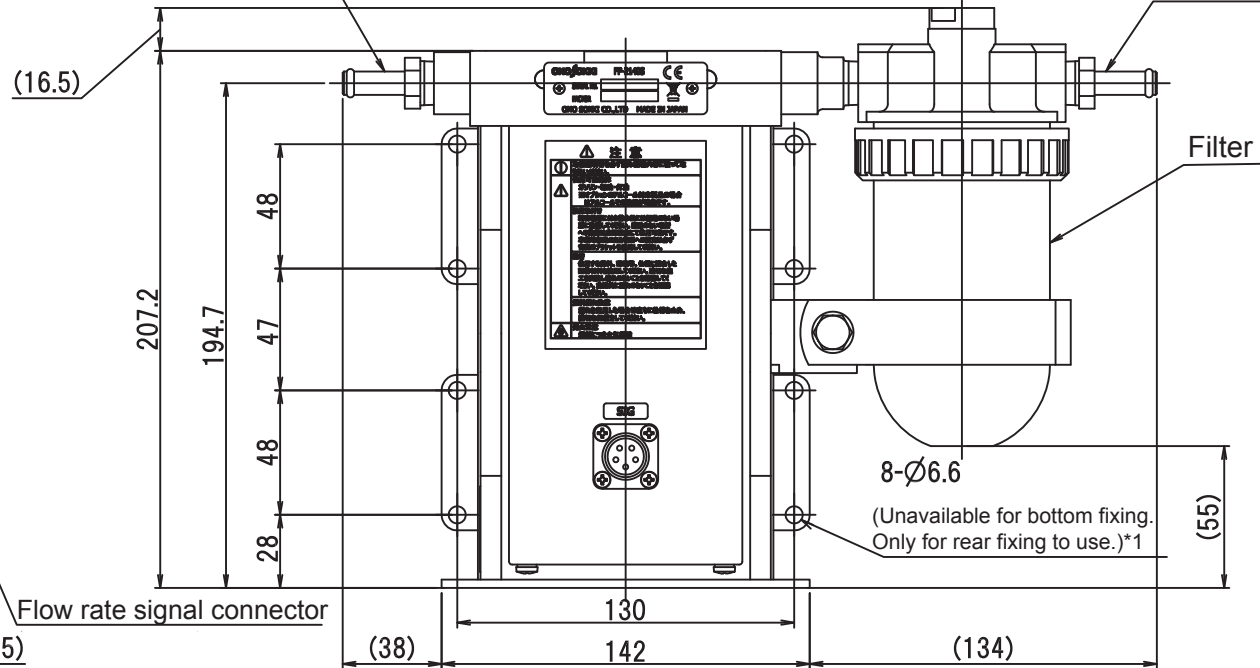

\*1: Do not fix with both sides (rear and bottom) to avoid distortion so that the measurement result will be not affected .

Weight: approx. 9 kg  
 Unit: mm

**FP-2104S**  
**ONOSOKKI**