

Linear Gauge Sensor

GS-3813B (Resolution:0.1 μm)

GS-3830B (Resolution:0.1 μm)

Instructions Manual

This instructions manual describes how to use GS-3813B/3830B Linear Gauge Sensors and also gives maintenance procedures, specifications and precautions.

Be sure to read through this manual before using the product.

Some of the precautions included in this manual, unless observed, may lead to damage to the product. Ono Sokki assumes no warranty or liability for any results arising from operations without observing the described instructions.

Keep this manual in a safe place after reading it.

Omission of Issuance of Certificate

This product has been tested under strict conditions for normal operation before shipment. Please note that the issuance of certificate is omitted.

Warranty

- This product is covered by a warranty for a period of one year from the date of purchase. Failures, if any, will be repaired for free of charge.
- Even during the warranty period, the following failures will be handled on a fee basis.
 - Failures or damages occurring through misuse, misoperation, or modification
 - Failures or damages occurring during transportation after purchase
 - Failures or damages occurring through natural calamities (fires, earthquakes, flooding, and lightning), environmental disruption, or abnormal voltage
 - Replenishment of expendable supplies, spare parts, and accessories
- For any questions such as those about repair after expiration of the warranty period, contact the dealer from which you purchased the product or the Ono Sokki sales office nearby.

ONOSOKKI CO., LTD.

WORLD WIDE
 1-16-1 Hakusan, Midori-ku,
 Yokohama 226-8507, Japan
 Phone : +81-45-935-3918
 Fax : +81-45-930-1808
 E-mail : overseas@onosokki.co.jp

Overview and Features

Overview

GS-3813B/3830B Series Linear Gauge Sensor is a detector that directly converts spindle displacement into electric signal using a displacement transducer of linear scale type. It enables precision measurement of dimensions by connecting Ono Sokki's Gauge Counter DG-5100.

Features

- High precision with resolution 0.1 μm
- IP66G protection structure tolerant to dust and wet
- High durability against sliding for 15 million times (accomplished in our endurance test)
- Electric circuit connectable to PLC
- Measurement automatable with optional air lifter

Part Names

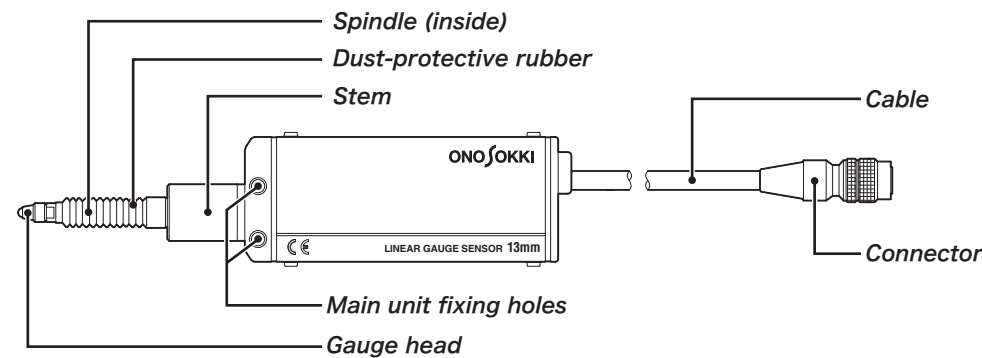

Output Connector Pin Assignments and Output Circuit

The figure below shows the GS-3813B/3830B Linear Gauge Sensor connector pin assignments, output circuit and phase relationships of output signals SIG1/SIG2 during spindle action. For GS-3813B/3830B, a pitch in output signal is equivalent to 0.4 μm.

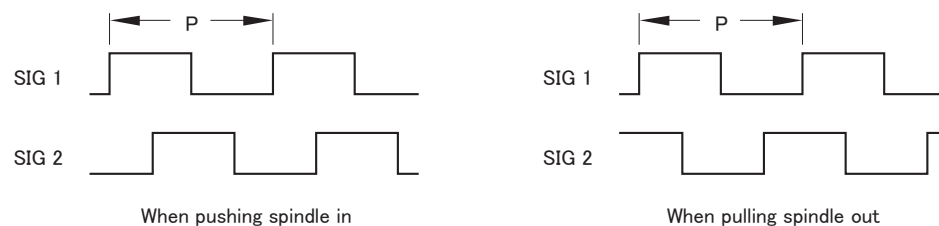
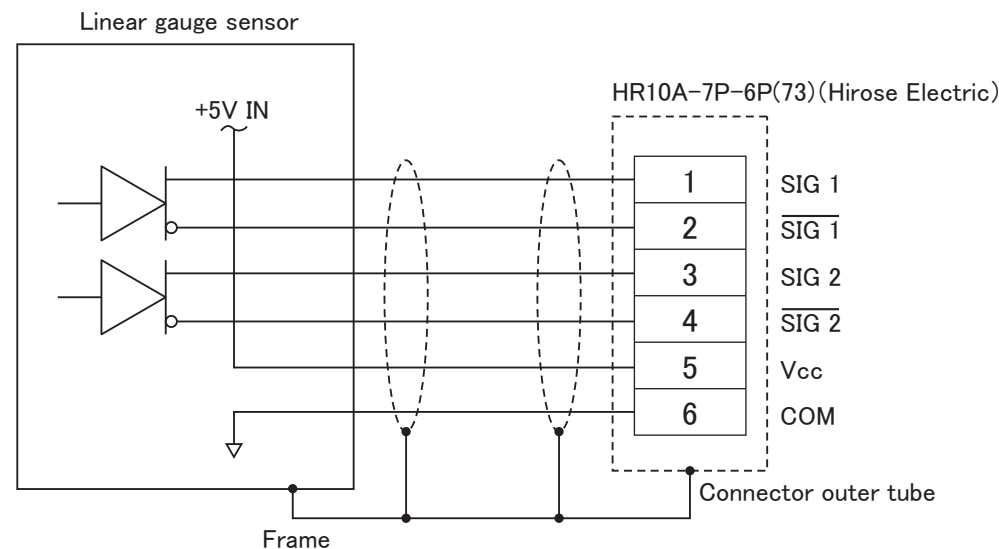

P=0.4 μm : GS-3813B/3830B

Precautions for Use

CAUTION This symbol is used to indicate precautions that, unless observed, may lead to injury to the operator or damage to the product.



- GS-3813B/3830B Linear Gauge Sensor is a precision instrument. Be careful not to let it fall or give strong vibration or shock to it.
- Do not disassemble GS-3813B/3830B Linear Gauge Sensor. Foreign substances, dust or liquid taken inside the instrument may cause failures. In addition, it will void IP66G warranty.
- Do not pull cables of GS-3813B/3830B Linear Gauge Sensor with force of 20N or more.

- When fixing GS-3813B/3830B Linear Gauge Sensor at its stem, use a collar, etc.; do not directly press screws, etc. against it.
- Do not rapidly release the spindle of GS-3813B/3830B Linear Gauge Sensor from its depressed position or do not make measurement in such a way. Do not stop it striking close to home to an internal stopper when you push up the spindle. It may cause degradation of the sensor accuracy or damage to the internal mechanism. For measurement requiring releasing of the spindle, the allowable range of release is 1mm or less from the object to be measured. Be sure to observe it.
- Do not tighten the stem of GS-3813B/3830B Linear Gauge Sensor with an excessive force. It may give adverse influence to movement of the spindle or reduce the sensor life. (For details, see "Mounting to Fixing Device.")

- Do not give lateral force (0.3N or more) to the spindle of GS-3813B/3830B Linear Gauge Sensor. It may give adverse influence to movement of the spindle or reduce the sensor life.
- When replacing the gauge head of GS-3813B/3830B Linear Gauge Sensor, take care not to give twisting force exceeding 0.3N·m to the spindle. (For details, see "Replacing Gauge Head.")
- Do not use GS-3813B/3830B Linear Gauge Sensor in environment with corrosive and/or flammable gas.
- Though GS-3813B/3830B Linear Gauge Sensor is applied with protective measures equivalent to IP66G, take further protective measures such as placing a cover to avoid direct exposure of the sensor to water or dust.

Mounting to Fixing Device

Mount GS-3813B/3830B Linear Gauge Sensor to the fixing device so that the spindle moving direction coincides with the length (displacement) direction of the object to be measured (see the figure below).

Before mounting, be sure to confirm the mounting location (see Outline Dimensional Drawing).

Mounting by squeezing stem

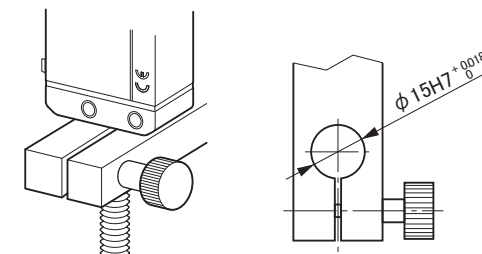

! Recommended tightening torque: 0.4 to 0.5 N·m

Mounting by squeezing stem using collar

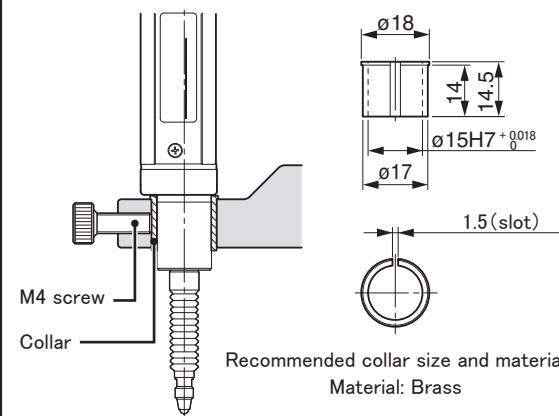

! Recommended screw: M4
 Recommended tightening torque: 0.4 to 0.5N·m

When squeezing the stem, note the following:

- After mounting, check movement of the spindle.
- If the spindle does not move smoothly, it is tightened excessively. Retighten the stem with less torque. Note that, with too little torque, the stem is not secured disabling accurate measurement (do not fix the stem by directly pushing with a screw).
- If the spindle moves smoothly after tightening the stem, it is tightened appropriately.

Mounting using the fixing holes on the main unit

When the sensor is mounted, there is a gap of approximately 0.2mm between the sensor top and the mounting surface.

Never try to eliminate this gap by pressing with brackets, etc.

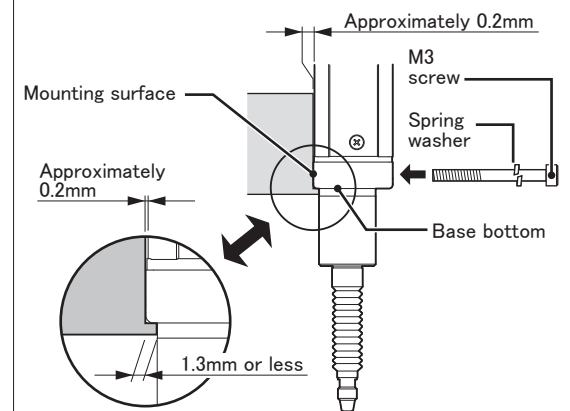

The mounting surface and base bottom of the sensor are made parallel and rectangular with the stem, respectively. Rectangular mounting can be accomplished easier by forming L-shaped lower end of the fixing jig.

M3 screw (male screw)	Fixing jig (female screw)	Recommended tightening torque (N·m)
Iron	Iron	0.7
Iron	Aluminum	0.52

Mount a rigid sensor fixing jig so that the spindle is rectangular with the object to be measured.

The recommended mounting angle is 0.15° (squareness 260 μm/100mm) or less.

The linear gauge sensor obliquely mounted will cause a lateral force to be applied to the spindle, resulting in failures.

Measurement

Procedures for measuring with GS-3813B/3830B Linear Gauge Sensor are as described below.

- Connect a gauge counter to the linear gauge sensor.
- Holding the gauge head with fingers, slowly move the spindle for measurement (move the spindle close to the measurement object until the gap is 1mm or less and then let the spindle fall).

! The spindle stopper inside the sensor is made of rubber. Therefore, it should not be used as the reference point for measurement. Use the point where the spindle is pushed in 0.2mm or more as the reference point.

Replacing Gauge Head

When replacing the gauge head of GS-3813B/3830B Linear Gauge Sensor, take care not to give twisting force exceeding 0.3N·m to the spindle.

- To prevent twisting force from being applied to the spindle, hold the flat part of the spindle with the attached spanner. At this time, take care not to touch the dust-protective rubber.
- Manually turn the gauge head to remove (secure) it. When removing (securing) the gauge head using pliers, etc., cover the gauge head with soft cloth to protect it.
- Note that turning force, if any, transmitted through the spindle to the inner mechanism of the sensor may cause misalignment of the spindle optical component, resulting in damage to the detector.

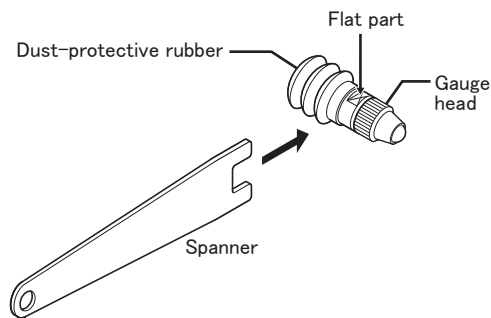

Replacing Dust-Protective Rubber

● Removing

Remove the gauge head in the steps given above.

Pull the dust-protective rubber out of the stem and then of the gauge head. Clean the entire dust-protective rubber.

● Installing

Before installing the dust-protective rubber, clean the spindle using absolute alcohol, etc.

Insert the dust-protective rubber up to the middle point between the stem and gauge head (see the figure below).

Slide the dust-protective rubber to groove A on the stem side and then to groove B on the gauge head side (see the figure below). Note that the spindle, if contaminated, may cause malfunction.

If the spindle is contaminated, clean it using absolute alcohol, etc. In addition, take care not to break the dust-protective rubber.

After installing the dust-protective rubber, check that the parting line (of mold) is not twisted. If the parting line is twisted, sufficient performance may not be attained.

After installing the dust-protective rubber, install the gauge head in the specified procedure (for details, see "Replacing Gauge Head").

● CAUTION

The dust-protective rubber is a consumable part. It requires periodic inspection.

Never remove the dust-protective rubber except for replacement. If it is damaged, contact the distributor from which you purchased the product or the Ono Sokki sales office nearby.

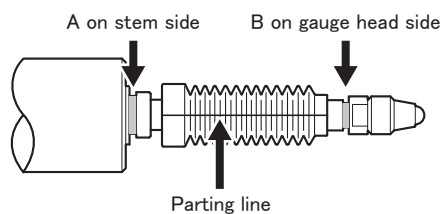

Outline Dimensional Drawing

● GS-3813B Outline Dimensional Drawing (mm)

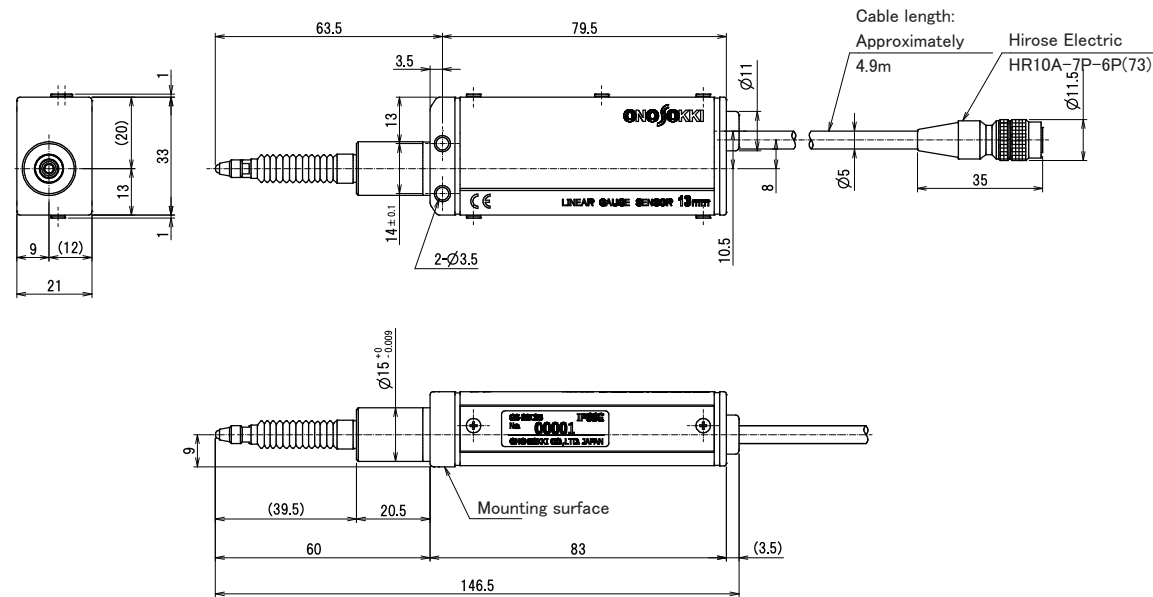

● GS-3830B Outline Dimensional Drawing (mm)

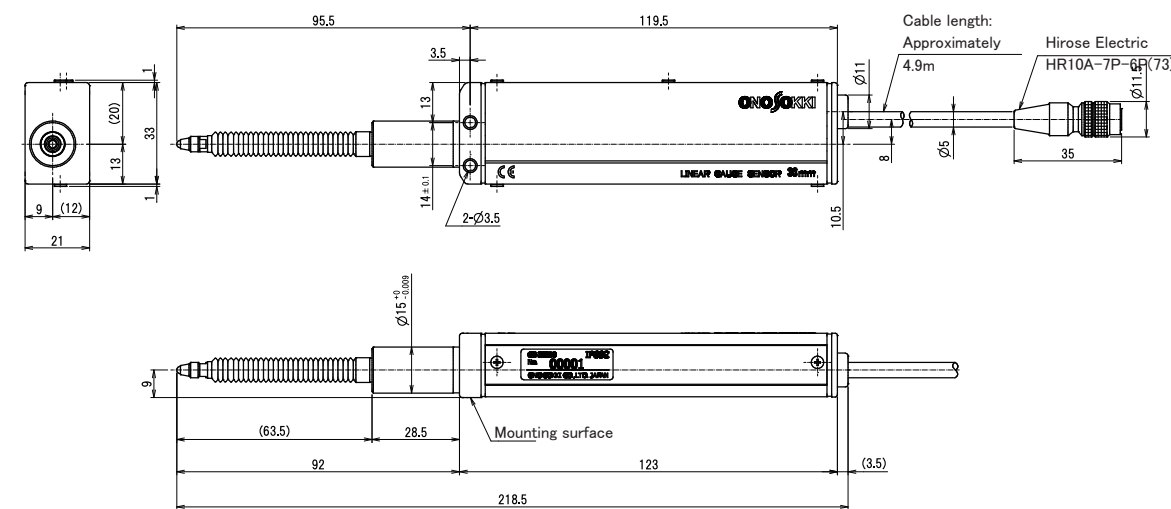

Troubleshooting

If the product seems to malfunction, check the points listed below before asking for repair. If the product still malfunctions after checking, contact your dealer or your nearest Ono Sokki sales office.

Phenomena	Causes	Countermeasures
Nonsmooth spindle movement	The stem is mounted with excessive force.	Do not tighten the step with excessive force.
	The dust-protective rubber is deteriorated by oil and/or chemicals.	The dust-protective rubber does not have sufficient resistance to oil or chemicals. After the dust-protective rubber is replaced with a new one, take measures for protecting it against oil and chemicals.
Unstable measurement values	The gauge sensor is not secured.	Fix securely the gauge sensor.
	The gauge head is mounted loose.	Mount securely the gauge head.
	Noise	Position the sensor cable as far as possible from noise generation sources such as power line and switching surge.
	Excessive vibration, shock or acceleration	Suppress vibration and shock given to the gauge sensor as much as possible.

Specifications

● Mechanical Specifications

Items	GS-3813B	GS-3830B
Measurement range (mm)	13	30
Resolution (μm)	0.1	
Accuracy (μm)	1 *1	
Max. response speed (m/s)	1.2 *2	
Measuring force in downward direction (N)	2.3 *3	2.7 *4
Vibration resistance (Power OFF) *5	196 m/s ² in each of three axes (75 minutes per each), 10 cycles of 10 to 150 Hz sweeping	
Shock resistance (Power OFF) *5	1960 m/s ² in each direction for each of three axes, 3 times for each of ±X, Y and Z, 18 times in total, sine half-wave, 6 ms operating time	

* 1 At 20 degrees C.

* 2 Value with our gauge counter DG-5100 used.

* 3 If upward direction, the spindle may not be returned completely.

* 4 If this detector is installed in lateral (at 10 degrees C or lower) or upward direction, the spindle may not be returned completely.

* 5 Vibration/shock resistance of mechanical specifications during measurement are not guaranteed.

● Electrical Specifications

Items	GS-3813B	GS-3830B
Supplied power	DC 4.5 to 5.5 V	
Consumption current	150 mA or less (5 VDC)	
Signal output	Line driver output type (equivalent to 26C31) Phase difference 90° ±20°	

● General Specifications

Operating temperature range	0 °C to +40 °C	
Storage temperature range	-10 °C to +55 °C (average annual humidity 75% or less) * No condensation permitted	
Cable length	Approximately 4.9 m *6	
Cable extension	Up to 30 m *7	
Mass	GS-3813B: Approximately 350 g / GS-3830B: Approximately 420 g (including cable)	
Accessories	Instructions Manual (this manual) x1, Spanner x1	
Protection Class	IP-66G	
Options	• Air lifter : AA-6102 (13 mm) / AA-6103 (30 mm) • Finger lift : AA-969	
* See the catalog for details.	• Gauge stand : ST-0230/044B • Dust-protective rubber (spare) : AA-4104 (13 mm) / AA-4105 (30 mm)	

* 6 Signal cable connector disconnection or remodeling will invalidate CE marking.

* 7 20 m when EMC applicable cable AA-8903 is used.

Applicable Standards

GS-3813B/3830B Linear Gauge Sensor has been designed and inspected observing the standards given below.

- CE marking EMC Command 2004/108/EC
EMC Standard EN61326-1 : 2006 Class A
- FCC Part15 Subpart A