

ONOSOKKI

Digital Engine Tachometer

SE-1200

Instruction Manual

Thank you for your selection of the SE-1200 Digital Engine Tachometer.
To ensure the performance of the SE-1200, please read this manual thoroughly.

Warnings and Cautions
In this document precautions are classified into two categories: WARNING and CAUTION. This depends on the degree of danger or damage possible if the precaution is ignored and the product is used incorrectly.

	WARNING This symbol is used to indicate precautions where there is a risk of death or serious personal injury to the operator if the product is handled incorrectly.
	CAUTION This symbol is used to indicate precautions where there is a risk of some personal injury to the operator or only material damage to the product if the product is handled incorrectly.

Copyright © ONO SOKKI CO.,LTD.
2007 All rights reserved.

Omission of Issuance of Certificate
This product has been tested under strict inspections for correct operation before shipment. Please note that the issuance of certificate is omitted.

- Warranty**
- This product is covered by a warranty for a period of one year from the date of delivery.
 - This warranty covers free-of-charge repair during the warranty period for defects occurred while the product is used under correct operating conditions according to descriptions in this manual and notices on the unit label.
 - For free-of-charge repair during the warranty period, contact your dealer or your nearest Ono Sokki sales office nearby.
 - Even during the warranty period, the following failures will be handled on a fee basis.
 - Failures or damages occurring through misuse, misoperation, repairing without ONO SOKKI'S approval.
 - Failures or damages occurring through mishandling (dropping) during transportation after purchase.
 - Failures or damages occurring by an Act of God (fires, earthquakes, flooding, and lightning), environmental disruption, or abnormal voltage.
 - Replenishment of expendable supplies, spare parts, and accessories.

This guarantee covers only the performance of the product itself only.
All inconvenience by the trouble of this product is not included.
*Outer appearance and specifications are subject to change without prior notice.
HOME PAGE: <http://www.onosokki.co.jp/English/english.htm>

WORLDWIDE
ONO SOKKI CO., LTD.
1-16-1 Hakusan, Midori-ku,
Yokohama 226-8507, Japan
Phone : 045-935-3976
Fax : 045-930-1906
E-mail : overseas@onosokki.co.jp

Observe the Following Points before Use

WARNING
Perform measurement using enough caution with the rotating section of the engine.
Perform measurement using enough caution with the high-temperature section of the engine.

CAUTION
Do not contact the equipment with the high-temperature section of the engine.
Since the equipment does not have sufficient heat resistance, be careful not to contact it with the high-temperature section (such as the exhaust pipe) of the engine.

Do not contact the equipment with any high-tension cord.
Contacting the equipment with any high-tension cord may cause malfunction or failure.
If there are two or more ignition coils, measurement is not possible.
Exact measurement may not be possible if the ignition system (distributor, high-tension cords, spark plugs, etc.) of the engine is defective.

If you do not use the equipment for a prolonged period of time, remove the batteries from the unit.
If you do not use the equipment for a prolonged period of time, exhausted batteries may cause leakage.

Do not use or store the equipment on locations subject to rapid temperature change.

Do not move the equipment from a hot place to a cold place or vice versa. There is a risk of condensation inside the equipment which may cause failure.

Do not get water, oil, dust, or other foreign materials inside the equipment.

Avoid using the equipment on locations exposed to water or oil or locations which are very humid or dusty.

CAUTION
Do not drop the product or apply excessive shock to it.
Since this product incorporates high-precision electronic parts, be careful not to drop it or apply excessive shock to it.

Wipe dirt off using a dry cloth or a cloth dampened with neutral detergent and squeezed firmly. Do not use volatile oils (thinner, benzene, etc.) or alcohols.

Overview

1. Overview

The SE-1200 Digital Engine Tachometer is a non-contacting type handy engine tachometer with built-in batteries and integrated detecting element, measurement section, and display.
The SE-1200 makes it possible to measure the rotational speed of a gasoline engine simply by bringing it close to the high-tension cords of the engine.

2. Features

- Compact light-weight body with a large-sized liquid crystal display
- Measurement in 1-r/min unit is possible at a large measurement range.
- Applicable to diverse gasoline engines including 2-stroke engines (with 1 to 4 cylinders) and 4-stroke engines (with 1 to 12 cylinders) with a setup of the number of cylinders.
- Memory function useful for checking measurement values (up to 10 results can be memorized)
- Over-range display function which fixes display value to maximum value and displays "ERROR" if measurement value exceeds each measurement range
- Continuously displays final measurement value for about 30 seconds upon completion of measurement

3. Unpacking

When you unpack the unit, make sure that you have all the following:

- SE-1200 main unit x1
- Type AAA dry battery x3
- Instruction manual x1

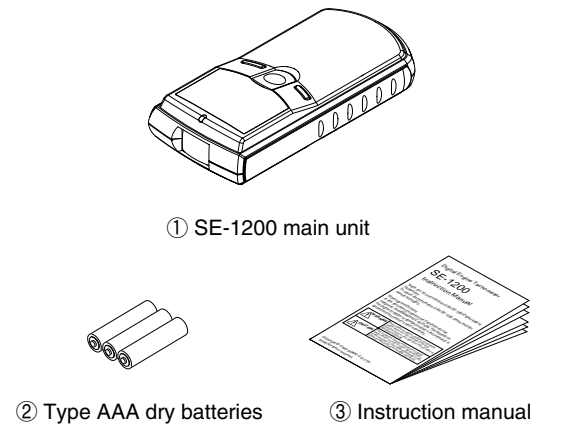

* Since the supplied batteries are samples, some may be exhausted quickly.

Option

- HT-0400 : Carrying case
- HT-0003 : Soft case

Storage

The storage temperature range of the SE-1200 is -10 to +60 . When you store it, avoid locations where the temperature is extremely high or low or the humidity is high. Store it in a place which is well-ventilated and not exposed to direct sunlight. If you do not use it for a prolonged period of time, be sure to remove the batteries to prevent accident caused by battery leakage, etc.

Name and Function of Each Section

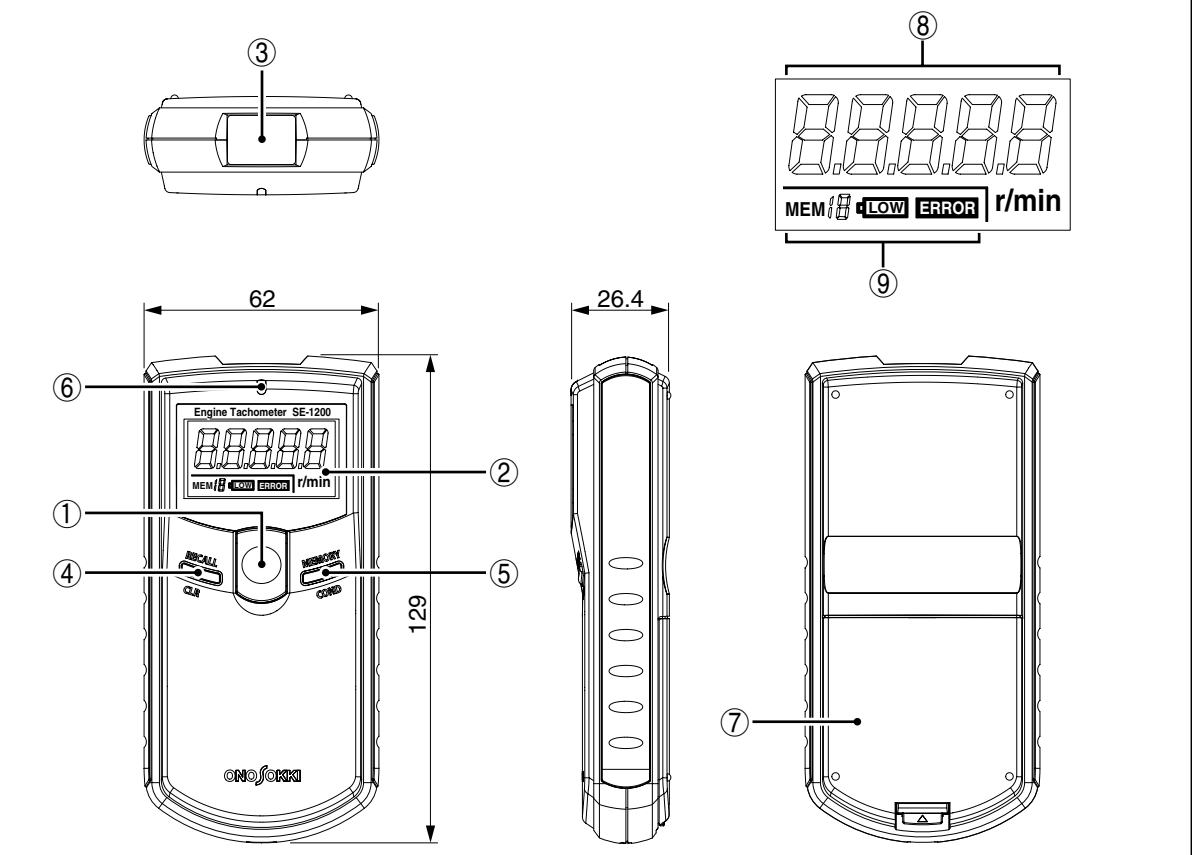

- ① Power switch
Turns the power ON or OFF.
Even if you release the power switch, the power ON condition is retained for 30 seconds.
- ② Display
Displays measurement values and various conditions.
- ③ Detecting element
Brought close to the high-tension cords of the engine to detect the rotational signal (ignition pulse).
- ④ RECALL/CLR switch
Recalls memorized measurement values and clears them at one time.
- ⑤ MEMORY/COND switch
Writes data in memory at the time of measurement, selects the setup mode, and changes settings.
- ⑥ Indicator (input signal indicator)
When the detecting element is detecting the rotation signal (ignition pulse), the LED indicator lights up.
- ⑦ Battery cover
Remove this cover to replace the batteries. Use three Type AAA dry batteries.
- ⑧ MAIN display
Displays measurement values and settings.
- ⑨ SUB display
Indicates the memory address (memory number), LOW battery, and error.

Power Supply

The SE-1200 operates on three Type AAA batteries.
If the batteries are exhausted and the LOW mark "LOW" appears, replace them with new ones. Be sure to replace all the three batteries at the same time.

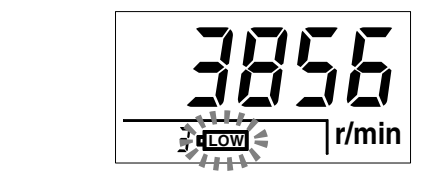

Battery replacement procedure
While pushing lightly the mark at the rear end of the battery cover with your finger, raise it to remove.
Put batteries properly in the battery compartment with the correct polarity (+/-).
Close the battery cover.

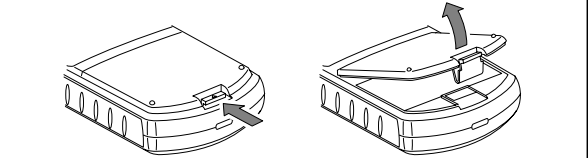

Operations

1. Setting the Number of Cylinders

Set the number of cylinders according to the type of the engine under measurement.

At the time of shipment, a 4-stroke 1-cylinder engine is set. Change the setting as required.

2-stroke	4-stroke	Number of Cylinders	Measurement Range (r/min)
	1 cylinder	- 1	100 to 20,000
1 cylinder	2 cylinders	1 2	100 to 20,000
	3 cylinders	- 3	100 to 20,000
2 cylinders	4 cylinders	2 4	100 to 20,000
	5 cylinders	- 5	100 to 20,000
3 cylinders	6 cylinders	3 6	100 to 20,000
4 cylinders	8 cylinders	4 8	100 to 15,000
	12 cylinders	- 12	100 to 10,000

If you press and hold the MEMORY/COND switch for at least 2 seconds, the number-of-cylinders setup mode is entered and the current setting is displayed in the MAIN display. Each time you press the MEMORY/COND switch in this mode, the number of cylinders is incremented. Set a value according to the table above.

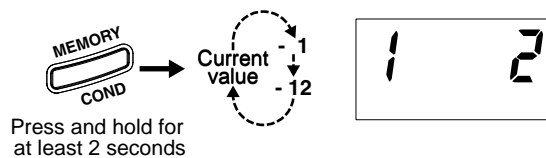

When you press the power switch to return to the measurement mode, the display value is applied. If you perform no switch operation for 30 seconds in the setup mode, the display value immediately before the power is turned OFF is applied.

2. Measurement

(1) In case of a 1-cylinder engine

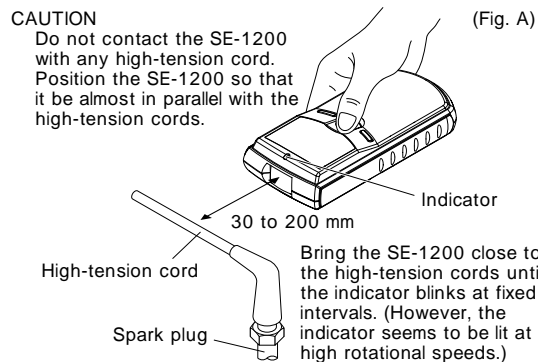

Press the power switch and then bring the detecting element close to the high-tension cords (ignition cords) of the engine as shown in Fig. A. The indicator of the SE-1200 starts blinking.

When you bring the SE-1200 closer from the position at which the indicator started blinking. The indicator blinks at fixed intervals in proportion to the rotational speed. (However, the indicator seems to be lit when the blinking interval remarkably shortens, i.e., at high rotational speeds.) This position is the measurement position.

The distance between the high-tension cords and the measurement position depends on the engine type. A rough standard is 30 to 200 mm.

(2) In case of a multi-cylinder engine with a distributor

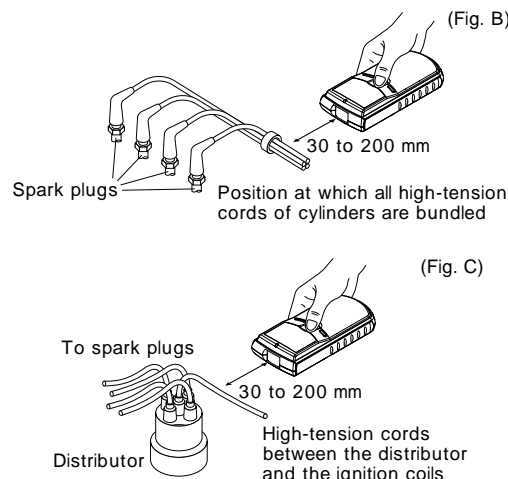

As shown in Fig. B and Fig. C, bring the SE-1200 close to the position at which all high-tension cords of cylinders are bundled or the high-tension cords between the distributor and the ignition coil.

As in the case of a 1-cylinder engine, perform measurement by bringing the SE-1200 at the position where the indicator blinks at fixed intervals in proportion to the rotational speed. If the measurement distance is too far or if the SE-1200 is brought close to the position where cords are not bundled, the blinking interval prolongs making it impossible to uniformly detect ignition pulse of each cylinder.

(3) In case of a multi-cylinder engine without a distributor

With the procedures mentioned in (2), perform measurement by bringing the SE-1200 close to the position where all high-tension cords of cylinders are bundled.

If there is no position where cords are bundled, the distance between the SE-1200 and each high-tension cord is not uniform, disturbing accurate measurement.

(4) Notes on measurement

Make sure that there is no obstacle between the SE-1200 and the high-tension cords. If there is an obstacle between the SE-1200 and the high-tension cords, the rotation signal (ignition pulse) is interrupted, disturbing accurate measurement.

Do not put your hand on the shaded section or the end of the SE-1200 as shown at right.

Putting your hand on the shaded section or the end of the SE-1200 will degrade the sensitivity, disturbing accurate measurement.

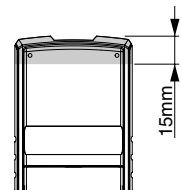

(5) Note on use

Do not contact the SE-1200 with the high-tension cords. In particular, since high voltage is present near the spark plugs, doing so may cause malfunction or failure.

If you accidentally contact the SE-1200 with the high-tension cords and irregular display is made, turn OFF the power switch and then back ON.

Since the SE-1200 does not have heat resistance, do not contact it with the high-temperature section (such as the exhaust pipe) of the engine. Perform measurement using enough caution with the rotating section of the engine.

3. Measurement Value Memory Function

(1) Memorizing Measurement Values

To memorize the current measurement value, press the MEMORY/COND switch in the measurement mode.

When the measurement value has been memorized, the number value in the SUB display is incremented.

Up to 10 measurement values can be memorized.

When you press the MEMORY/COND switch after memorizing 10 measurement values, "FULL" is displayed in the MAIN display for about a second, indicating that no more values can be memorized.

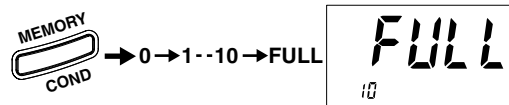

(2) Calling Measurement Values

Memory values can be called by pressing the RECALL/CLR switch in the measurement mode.

The memory number is displayed as "MEM XX" (for example, MEM 5) in the SUB display.

Memory values are called from the latest memory number and then in order of memory number, MEM 1, MEM 2, MEM 3, ... and MEM 10.

If there are three memory values, the value of MEM 3 is displayed first. Then, the SUB display displays MEM 4 and the MAIN display displays "-----" indicating that there is no measurement value memorized. Therefore, if there is no memory value, "-----" is displayed for MEM 1.

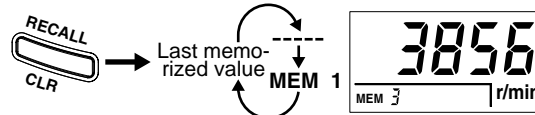

If you press the power switch to enter the measurement mode or if you perform no switch operation for 30 seconds in the RECALL mode to turn OFF the power, the RECALL mode is exited.

(3) Clearing (all) memorized values

To clear the memory contents, press the RECALL/CLR switch for at least 2 seconds.

When the memory has been cleared, "CLR" is displayed in the MAIN display for about one second.

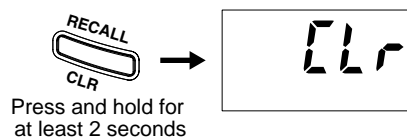

4. SUB Display

ERROR Display

If a measurement value exceeds each measurement range, the MAIN display value is fixed to the maximum value and the ERROR mark "ERROR" appears in the SUB display.

The maximum rotational speed which can be measured by the SE-1200 is 20,000 r/min.

LOW Battery Display

If the LOW mark "LOW" lights up, it indicates that the dry batteries have been exhausted.

- This mark lights up if the battery voltage drops to 3.3 V or lower.
 - If the mark lights up, immediately replace the three dry batteries with new ones.
- Using the exhausted batteries may disable measurement.

Specifications

1. Measurement Section

Measurement unit : 1 r/min

Measurement range :

Number of Cylinders	2-stroke	4-stroke	Measurement Range (r/min)
- 1		1 cylinder	100 to 20,000
1 2	1 cylinder	2 cylinders	100 to 20,000
- 3		3 cylinders	100 to 20,000
2 4	2 cylinders	4 cylinders	100 to 20,000
- 5		5 cylinders	100 to 20,000
3 6	3 cylinders	6 cylinders	100 to 20,000
4 8	4 cylinders	8 cylinders	100 to 15,000
- 12		12 cylinders	100 to 10,000

Measurement accuracy : 100 to 12,499 r/min ± 1 r/min
12,500 - 20,000 r/min ± 2 r/min

Over-range display : If a measurement value exceeds each measurement range, the MAIN display value is fixed to the maximum value and the ERROR mark "ERROR" appears in the SUB display.

2. Detecting Element

Applicable engines : Gasoline engines
2-stroke (1, 2, 3, or 4 cylinders)
4-stroke (1, 2, 3, 4, 5, 6, 8, or 12 cylinders)

Detection system : Detects discharge noise of the spark plugs.

Detection distance : 30 to 200 mm

Object under detection : High-tension cords

3. Display

Number of display digits : 5 digits

Character height : 10.5 mm

Indicator : 7-segment LCD

Refresh time : 1 second (2 seconds if a detected signal exceeds 1 second)

4. Measurement Mode

Data hold function : When measurement is completed, the display of the last measurement value is retained for about 30 seconds and then automatically turns off (auto power off).

Memory function : A measurement value is stored in memory each time the MEMORY/COND switch is pressed. Up to 10 measurement values can be memorized. Since these values are stored in non-volatile memory, they are retained even after you turn OFF the power.

5. General Specifications

Power supply : Type AAA dry battery (x3)
Continuous operating time : About 100 hours (with alkali dry batteries at 20)

Battery LOW display : When the battery voltage drops to 3.3 V or lower, the LOW mark "LOW" lights up.

Operating temperature range : 0 to +40

Storage temperature range : -10 to +60

Operating humidity range : +35 to +85%RH (without condensation)

Storage humidity range : +35 to +85%RH (without condensation)

Mass : About 90 g (dry batteries not included)

Dimensions : 129 x 62 x 26.4 mm

Troubleshooting

If you perceive any abnormal condition, first check the following points. If the instrument does not operate normally after check, contact your dealer (Ono Sokki agency) or Ono Sokki sales office nearby.

Symptom	Check Point	Countermeasure
No display	Are batteries set ? Is the battery polarity correct ? Are batteries exhausted ? Does the display recover after replacing the batteries ?	Set batteries. Change the battery polarity correctly. Replace all batteries with new ones. Perform the reset operation. 1. Remove the batteries. 2. Press and hold the power switch for several seconds. 3. Set the batteries.
Unstable display	Is the measurement distance appropriate ? Is the SE-1200 contacted with the high-tension cords ? Are there any obstacles between the SE-1200 and the high-tension cords ? Is your hand put on the end of the SE-1200 ?	The measurable distance is 30 mm to 200 mm from the high-tension cords. Use the SE-1200 within this range. Do not contact the SE-1200 with the high-tension cords. Remove obstacles between the SE-1200 and the high-tension cords. Do not place your hand because doing so will degrade the sensitivity.
Display value different from actual value	Is the setting of the number of cylinders appropriate ? Is the measurement distance appropriate ?	Set an appropriate number of cylinders according to the engine type under measurement. The measurable distance is 30 mm to 200 mm from the high-tension cords. Use the SE-1200 within this range.